

YCS1/D0.6Z22——0.6A 700V SSR

概述 Features

- 过零型 Zero-cross
- 负载电流至0.6A Load current up to 0.6A
- 阻断电压700V Repetitive peak off-state voltage 700V
- 介质耐压5000V Dielectric strength 5000V
- 符合RoHS RoHS compliant



应用 Applications

- 家电产品（空调、冰箱、洗衣机、微波炉、卫浴）
Home appliances (air conditioners, refrigerators, washing machines, microwave ovens, personal hygiene product etc.)
- LED灯控制 LED control
- 工业控制 Industrial control

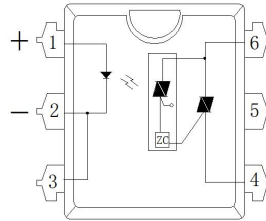

打印标志 Marking information

Part number	Package	Marking
YCS1/D0.6Z22S	SMD6	YCS1 D0.6Z22

极限值/Absolute maximum ratings

(Ta=25°C)

特性参数/Parameter		符号/Symbol	测试条件/Test condition	最小值/Min.	典型值/Typ.	最大值/Max.	单位/Unit
输入端/Input	LED 反向电压/LED reverse voltage	V_R		6			V
	LED 正向电流/LED forward current	I_F				50	mA
输出端/Output	阻断电压/Repetitive peak off-state voltage	V_{DRM}/V_{RRM}		700			V
	额定电流/On-state RMS current	$I_{T(RMS)}$	$I_{in}=10mA$			0.6	A
	浪涌电流/Surge current	I_{TSM}	50Hz, 1 cycle		6		A
介质耐压/Dielectric strength *		V_{ISO}	$I_{ISO} \leq 0.3mA$	5000			V_{rms}
工作温度/Operating temperature		T_{opr}		-30		85	°C
储存温度/Storage temperature		T_{stg}		-40		125	°C

“*”：RH=40 to 60%, T=20~30°C, AC for 1minute.

电参数 Electrical parameters

(Ta=25°C)

特性参数/Parameter		符号 /Symbol	测试条件 /Test condition	最小值 /Min.	典型值 /Typ.	最大值 /Max.	单位 /Unit
输入端/Input	LED 正向电压 /LED forward voltage	V_F	$I_F=10mA$		1.2	1.3	V
	LED 反向电流/LED reverse current	I_R	$V_R=5V$			10	μA
输出端/Output	断态泄漏电流/Output off-state leakage current	I_{DRM}	$V_{DRM}=700V$			10	μA
	断态泄漏电流/Output off-state leakage current	I_{RRM}	$V_{RRM}=700V$			10	μA
	维持电流/Holding current	I_H				50	mA
	电压指数上升率 /Critical rate of rise of off-state voltage	dv/dt	$V_{DRM}=600V*1/\sqrt{2}$	200			V/ μs
耦合特性 /Transfer characteristics	LED 触发电流/LED trigger current	I_{FT}			3	8	mA
	推荐的工作电流 /Recommend operating current	I_{in}		10		18	mA
	导通电压降/Output on-state voltage drop	V_T	$I_{in}=10mA,$ $I_t=0.6A$ $V_D=6V$		1.1	2.0	V
	过零电压/Zero-cross voltage	V_{zc}	$I_{in}=10mA,$ $I_t=0.6A$		10	20	V
	导通时间/Turn on time	T_{on}	$I_{in}=10mA,$ $V_D=6V, R_t=100\Omega$			1+1/2cycle	ms
	关断时间/Turn off time	T_{off}				1+1/2cycle	ms

外形尺寸 Outline dimension :mm

1、SMD6

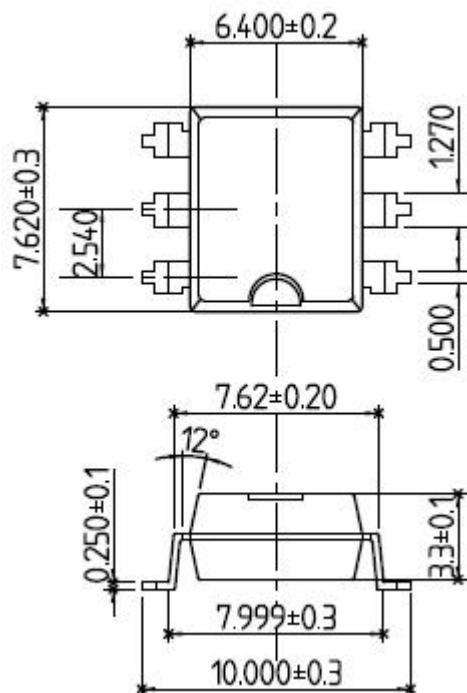

订货信息 Ordering information

订货信息/Ordering information								
	Y	CS	1/	D	0.6	Z	22	S
公司商标代号 Company symbol								
交流输出型 AS SSR								
封装 Package: 1: DIP6								
输入端电流型 Current driving: D								
负载电流 Load current: 0.6—0.6A								
P:调相型 Non zero-cross Z:过零型 Zero-cross								
负载电压 Load voltage: 22:220Vac;38:380Vac								
S :SMD								

安规要求 Safety and insulation ratings

爬电距离	Creepage distance	5.0mm, CTI \geq 275;
瞬时过电压	Highest allowable overvoltage	5000V;
再现峰值电压	V_{IORM}	769V;
局部放电	Partial discharge test voltage Method b, $V_{Pd} = V_{IORM} \times 1.6$	1230V.

特性曲线 Characteristic data

1. 负载电流与环境温度关系曲线
Load current VS. ambient temperature

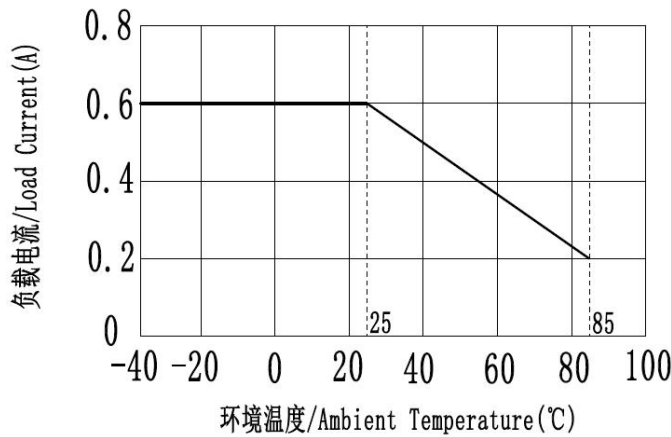

接通和关断时间关系 Turn on and turn off time

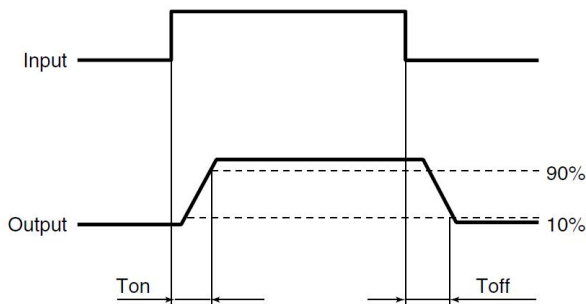

接线图 Wiring diagram

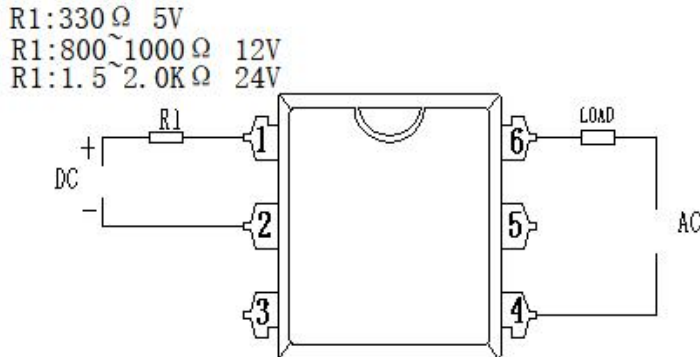

注意事项 Notes

- 工作环境温度超过 25℃ 时请降额使用。参见特性曲线 1。
When ambient temperature is above 25℃, the load current must be reduced. (see characteristic data)
- 继电器接线时，务必保证输入端极性的正确，以免损坏继电器。
Ensuring the polarity is correct when connecting the input lines, otherwise the wrong connection will damage the relay.
- 由于 SSR 动作时间很短，输入端的噪声可能会引起 SSR 误动作，所以在输入端环境噪声较大时，应在输入端接 R/C 回路吸收噪声。
Since the operate time of the relay is extremely short, any noise to input terminal will cause malfunction of the SSR, So a RC circuit should be connected to input terminal to absorb the noise in the noisy condition.

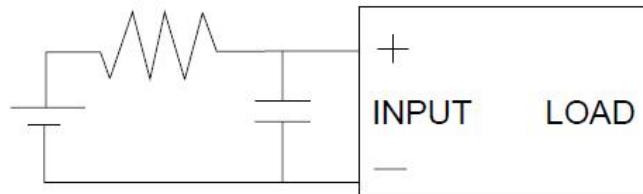

- 推荐的使用电路，输出端的尖峰电压可能会引起 SSR 误动作，所以请在输出端应加 R/C 回路或压敏电阻吸收尖峰电压，具体见下图：
Below shows a recommend circuit: Please add a RC circuit or varistor on the load side, as noise/surge could damage the unit or cause malfunctions.

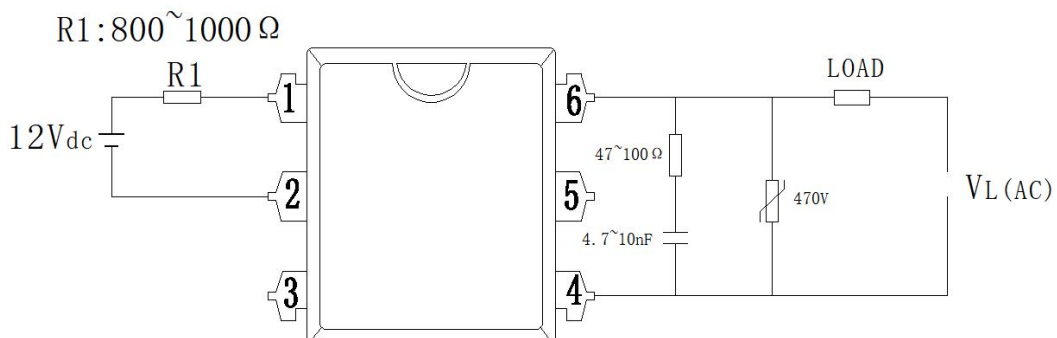

关于防静电对策 **Cautions for static electricity**

- a. 使用电烙铁时,对电烙铁前端进行接地。(建议使用低电压用的电烙铁。) When using soldering irons, either use irons with low leakage current, or ground the tip of the soldering iron. (Use of low-voltage soldering irons is also recommended.)
- b. 组装时使用的设备等也应正确的接地。 Devices and equipment used in assembly should also be grounded.

关于焊接 **Soldering**

继电器焊接,260℃情况下焊接时间不能超过 10 秒钟,350℃情况下焊接时间不能超过 5 秒钟。
Soldering must be completed within 10 seconds at 260℃ or within 5 seconds at 350℃.